

EXPLODED VIEW

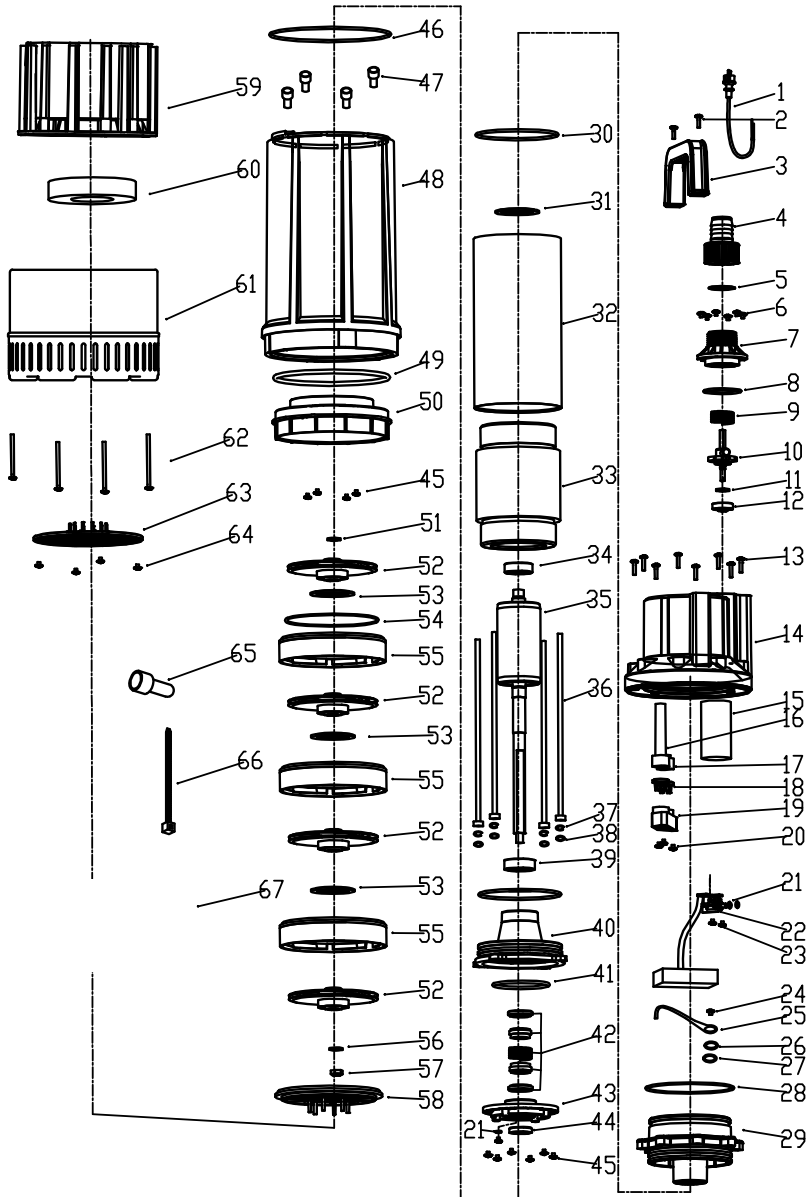

PARTS LIST

No	description	No	description
1	cable&plug	32	Motor barrel
2	screw	33	stator
3	handle	34	bearing
4	output jointor B	35	rotor
5	seal	36	flat gasket
6	screw	37	gasket
7	output jointor A	38	flat gasket
8	O shape ring	39	bearing
9	spring	40	front cover
10	check valve	41	O shape ring
11	flat gasket	42	machanism seal
12	screw-plastic	43	oil cavity cover
13	screw	44	frame seal ring
14	back cover	45	screw
15	capacitance	46	O shape ring
16	cable jacket A	47	screw
17	cable jacket B	48	main pump body
18	cord plate	49	O shape ring
19	Cord buckle	50	basic
20	screw	51	ss-gasket
21	O shape ring	52	impeller
22	breadboard	53	gasket
23	screw	54	O shape ring
24	screw	55	difuser
25	washer	56	gasket
26	Grounding metal block	57	screw
27	gasket	58	Locating ring
28	O shape ring	59	cover
29	rotor back cover	60	filter
30	O shape ring	61	SS basic
31	gasket	62	screw
		63	basic board
		64	screw
		65	connection cap (L)
		66	ribbon
		67	desiccant